

Fuzzy Knowledge-Based Control for Backing Multi-Trailer Systems

Andri Riid, Jaakko Ketola and Ennu Rüstern, *Member, IEEE*

Abstract—This paper embraces the problem of controlling backward movements of multi-trailer systems (in present case trucks with three and four trailers) by the means of fuzzy logic. It is shown that decomposition of the problem is a great help when finding the solution, however, as the number of trailers increases, it becomes increasingly complex to find a satisfying solution as the control object itself becomes less and less controllable.

I. INTRODUCTION

ANYONE who has ever tried backing up a car with a trailer knows how complicated it is and how easily it can go wrong. In fact, even experienced drivers have difficulties and will need to go forward and backward numerous times in order to position the truck at the dock properly. If the driver is not allowed to make forward movements, successful backing becomes unlikely. One particularly nasty property of the truck backer-upper is so called *jackknifing* that means a condition where the cab and trailer are jammed together at 90°. Once it occurs the control over the system is lost so understandably it is very important to avoid jackknifing that actually can happen very easily when backing the truck.

Due to its interesting properties, truck backer-upper has appeared as a test object in a large number of scientific contributions [1-14] since its introduction in the paper of Nguyen and Widrow [15]. Very few researchers, however, have ventured outside the scope of the original problem, i.e. tried their luck on backing up the trucks with more trailers than just one. Although backing of multi-trailer systems has perhaps little practical significance (the trailers can be detached and backed individually if the need arises), it is nonetheless a very challenging and increasingly complex control problem as the number of attached trailers grows that can be investigated just for the fun of that.

The most outstanding attempts of handling multi-trailer systems that can be found from scientific literature are probably presented in the works of Tanaka *et al.* [16-18], where they have managed to maintain control over the systems with no less than 10 trailers by representing the vehicle model by a Takagi-Sugeno fuzzy model and then solving the controller design problem in terms of linear

matrix inequalities. However, the control goal in these contributions has been restricted to stabilizing the system along the x -axis

In our previous works [19-22], on the other hand, we have worked on a knowledge-based fuzzy control approach to obtain a controller capable of backing the truck from virtually arbitrary initial position to a freely chosen destination. The key idea is to decompose the control task in a manner what would facilitate efficient control knowledge acquisition and would result in improved control quality. Initially this principle was applied to the simplest case of backing control – a trailerless truck [19]. In subsequent papers we have managed to show that the approach also works with more complex cases of truck backing – one trailer truck in [20] and two-trailer system in [21]. Although the approach stems from the paradigm of knowledge-based control and is therefore dependent on the designer abilities and the stability conditions cannot be shown explicitly, it highly benefits from the hierarchical structure of the control system that helps us to focus our knowledge and common sense-based reasoning and has so far produced successful results.

The logical next step is to extend the approach to even more complex cases of multi-trailer systems. While we are able to find the solutions for three- and four-trailer systems in current paper, it turns out that it becomes more and more difficult to find a satisfying solution both in terms of maneuverability and stability as the number of trailers grows (each additional trailer increases the potential for jackknifing substantially), which implies that apparently, the potential of given approach has been thoroughly exhausted.

II. SYSTEM DEFINITION

The driving system (or the car as we shortly address it throughout the paper) consists of the cab part and N attached trailers (Fig. 1) and is described by $N + 3$ state variables – the coordinates (x, y) of the reference point placed at the end of the last (N -th) trailer and $\Phi_0, \Phi_2, \Phi_4, \dots, \Phi_{2N}$ that are the angles between the x -axis and car components - the cab part, first trailer, second trailer, third trailer etc. up to the N -th trailer. These angles are also shortly addressed as orientations of respective components of the car in this paper. The length (l) and the width (w) of the cab part are both 2m and the dimensions of trailers are 2×4m.

The main challenge is to design a control system that is able to provide an appropriate steering angle θ throughout the backing cycle so that the car will ultimately be positioned at $x = x_f, y = y_f$, at the expected angle $\Phi_{2N} = \Phi_f$

Andri Riid is with the Department of Computer Control of Tallinn University of Technology, Ehitajate tee 5, Tallinn 19086, Estonia (phone: +372-6202-109; fax: +372-6202-101; e-mail: andri@dcc.ttu.ee).

Jaakko Ketola is with Lappeenranta University of Technology Laboratory of Applied Mathematics, P.O. Box 20, FIN-53851 Lappeenranta, Finland (e-mail: jaakko.ketola@lut.fi).

Ennu Rüstern is with the Department of Computer Control of Tallinn University of Technology, Ehitajate tee 5, Tallinn 19086, Estonia (e-mail: ennu.rystem@dcc.ttu.ee).

(that defines so-called loading dock that is pre-specified).

The kinematics of the system consisting of the truck and N trailers are governed by $2N + 3$ equations (taken from [17]) and presented here in general form ($j = 1, \dots, N$)

$$\begin{aligned} \Phi_0(k+1) &= \Phi_0(k) + \frac{v \cdot \Delta t}{L} \tan \theta(k) \\ &\dots \\ \Phi_{2j-1}(k) &= \Phi_{2(j-1)}(k) - \Phi_{2j}(k) \\ \Phi_{2j}(k+1) &= \Phi_{2j}(k) + \frac{v \cdot \Delta t}{L} \sin \Phi_{2j-1}(k) \\ &\dots \\ y(k+1) &= y(k) + v \cdot \Delta t \cos \Phi_{2N-1}(k) \sin \left(\frac{\Phi_{2N}(k+1) + \Phi_{2N}(k)}{2} \right) \\ x(k+1) &= x(k) + v \cdot \Delta t \cos \Phi_{2N-1}(k) \cos \left(\frac{\Phi_{2N}(k+1) + \Phi_{2N}(k)}{2} \right) \end{aligned} \quad (1)$$

where $-90^\circ \leq \Phi_1 \leq 90^\circ$ is the difference between the orientations of the cab and the first trailer and $-90^\circ \leq \Phi_{2j-1} \leq 90^\circ$ are the similar orientation differences of consecutive trailers (we address these as joint angles); L (5m) is the added length of a trailer and its joint, $v = -1\text{m/s}$ is backward driving speed and $\Delta t = 0.1\text{s}$ is the sampling time. Also note that steering angle θ is restricted to $[-70^\circ, 70^\circ]$.

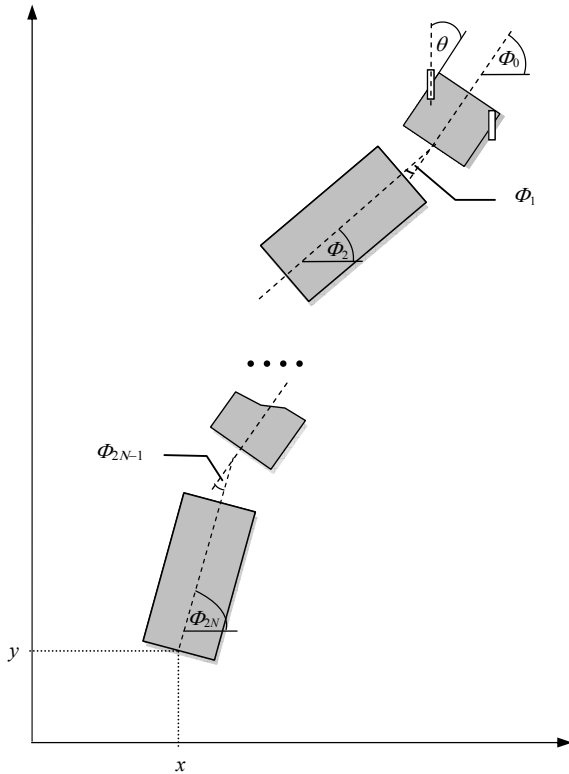

Figure 1. A multi-trailer car with N trailers

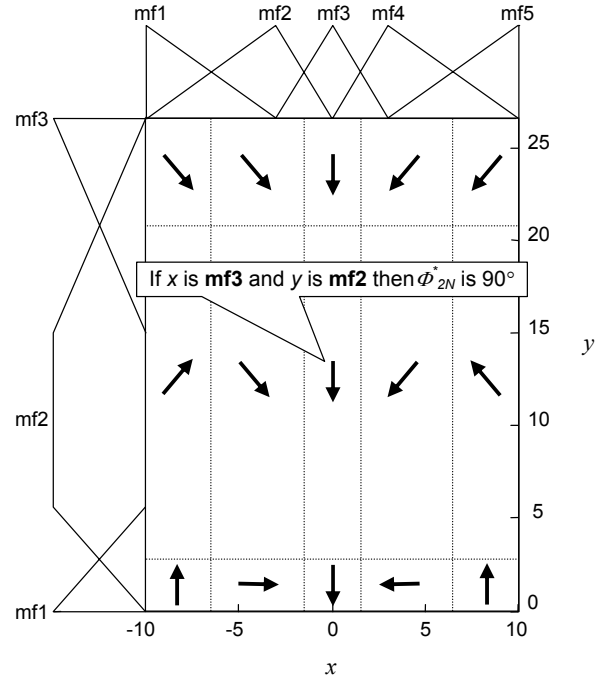

Figure 2. 15 TMU rules responsible for trajectory management when $y > 0$. Each small arrow indicates optimal angle of the car corresponding to the given rule

III. THE CONTROL SYSTEM

As shown in [21], the control system for car backing can be built from relatively simple building blocks that are connected according to the configuration of given control object and then tuned for best performance with the help of gain coefficients. The most important of these building blocks is the Trajectory Management Unit (TMU) that is responsible for specifying the optimal orientation for the rearmost trailer throughout the journey from the initial position to the designated one, guaranteeing that it would eventually reach the loading dock at the right angle (Φ_j). TMU is in fact made up from two separate components – upper TMU (Fig. 2) that is supposed to act when car is operated in the range of positive values of y and lower TMU (Fig. 3) that takes over when the car reaches the area of negative values of y . Both of these are quite simple fuzzy systems (especially the lower one) that can be configured easily as the general idea of about trailer trajectories is very intuitive and can be put down in terms of fuzzy logic effortlessly.

In addition to that, for all existing N joints separate joint controllers are designed that coordinate the interaction between consecutive trailers (including the cab and the first trailer). The aim of these joint controllers is to produce assumed optimal values of the joint angle Φ_{2j-1} (denoted by Φ_{2j-1}^*) corresponding to current error of the next joint angle ($\Phi_{2j+1} - \Phi_{2j+1}$). It follows naturally that if the latter is positive, the former must be negative to reduce the error (and vice versa) and thus the dependence must be

monotonously decreasing. This single-input single-output functional block is again implemented using fuzzy logic in order to obtain a nonlinear mapping (Fig. 4) that is necessary to achieve satisfying control performance as was found in [20]. Finally, the difference between expected joint angle of the N -th joint and its actual value is used as an error function for the PD controller defining the steering angle. For three- and four-trailer systems, the reasoning above leads to the principal control schemes depicted in Figs 6 and 7, respectively.

IV. CONFIGURING THE CONTROL SYSTEM

In order to achieve good control performance add-ons and further adjustments to the control system depicted in Fig. 5 are required that will be explained in detail in this section. First of all, we need to coordinate the cooperation of upper and lower TMUs with a switching block (Fig. 5) that will see to it that for positives values of y , Φ_{2N}^* will be supplied by upper TMU and for negative values by its respective counterpart. The effect from using hard limiters at the inputs of the TMUs is twofold. First, they are absolutely necessary to guarantee that values of x and y will always be within the universes of discourse of respective input variables of the TMU. Secondly and very conveniently, these limiters also ensure that car navigation will be governed by appropriate rules even when x and y actually appear to be outside of the scope of original TMUs. The gain coefficients k_{xu} , k_{xl} and k_y applied to the same inputs, on the other hand, allow us to adjust the TMUs to the characteristics of the driving system (multi-trailer systems are much longer and thus require longer trajectories than the single truck, which the TMUs have been originally optimized for) and with each other to ensure flawless cooperation. Exactly the same reason calls for the corrective measure of k_{shift} that will be deducted from the value of y fed to the upper TMU – it shifts the rules of the TMU away from the x -axis so that there will be enough space for the u-turn the car is required to make when returning from the negative half-plane.

Secondly, fuzzy systems in Figs 2 and 3 are constructed under the assumption that $x_f = 0$, $y_f = 0$, $\Phi_f = 90^\circ$. In order to save ourselves from redesigning these blocks each time the position and/or the orientation of the loading dock is changed, an interface is built between the actual values of x , y , Φ_{2N}^* and those that will be used for the computations in the subsystem in Fig. 5 (which are denoted by x' , y' and Φ_{2N}' in Fig. 8).

The values of x' and y' are obtained using the following formulas:

$$x' = r \cos(90^\circ - \Phi_f + \Phi_{2N}) \quad (1)$$

$$y' = r \sin(90^\circ - \Phi_f + \Phi_{2N})$$

where

$$r = \sqrt{(x - x_f)^2 + (y - y_f)^2}. \quad (2)$$

Setpoint value corresponding to the given destination (x_f , y_f , Φ_f) is computed by

$$\Phi_{2N}^* = \Phi_r + \Phi_f - 90^\circ. \quad (3)$$

In result, through all these adjustments, the TMU block in Fig. 5 is updated to the current driving goal and physical characteristics of the controlled object and, in a manner of speaking, generates a virtual force field in the driving area as depicted in Fig. 9.

The joint controllers for each j -th joint are “localized” with individual gain coefficients $k_x(JCj)$ (applied to the input of the JC) and $k_y(JCj)$ (applied to the output of the JC) as can be seen in Fig. 10. The value of $k_y(JCj)$ allows us to prescribe the maximum values of the j -th joint angle. A higher value of $k_y(JCj)$ means more manoeuvrability in j -th joint and vice versa. For obvious reasons the joint angle must be kept smaller than 90 degrees. $k_x(JCj)$ on the other hand specifies how sensitive the joint controller is to the changes in joint angle error. A joint controller with a high value of $k_x(JCj)$ responds very energetically to the changes in joint angle. As we see in the following sections, proper determination of all these coefficients is critical to the overall success

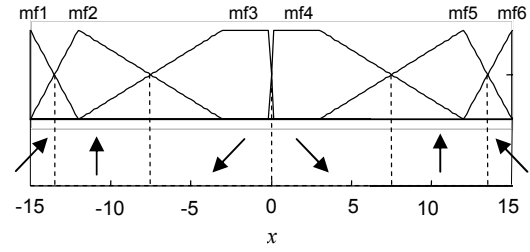

Figure 3. Trajectory mapping unit (lower part)

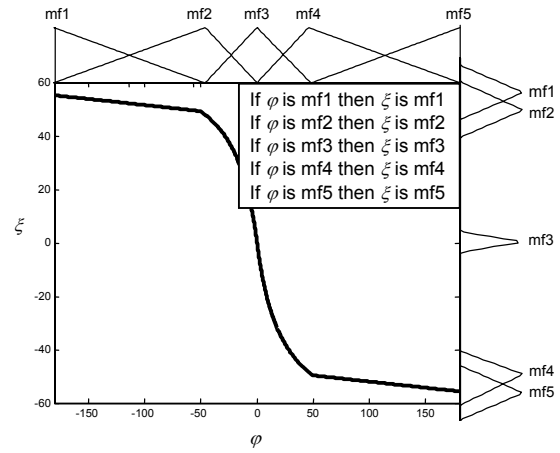

Figure 4. Joint controller. $\xi = \Phi_{2j-1}^*$, $\varphi = \Phi_{2j+1}^* - \Phi_{2j+1}$

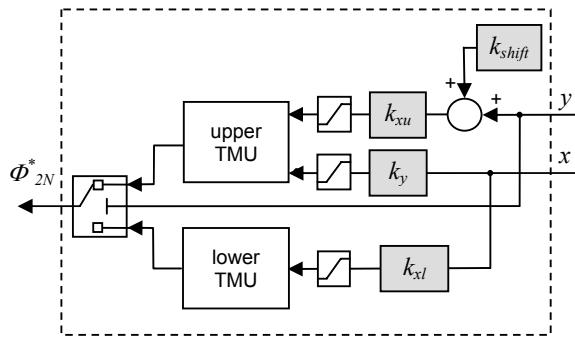

Figure 5. Coordination of the TMUs

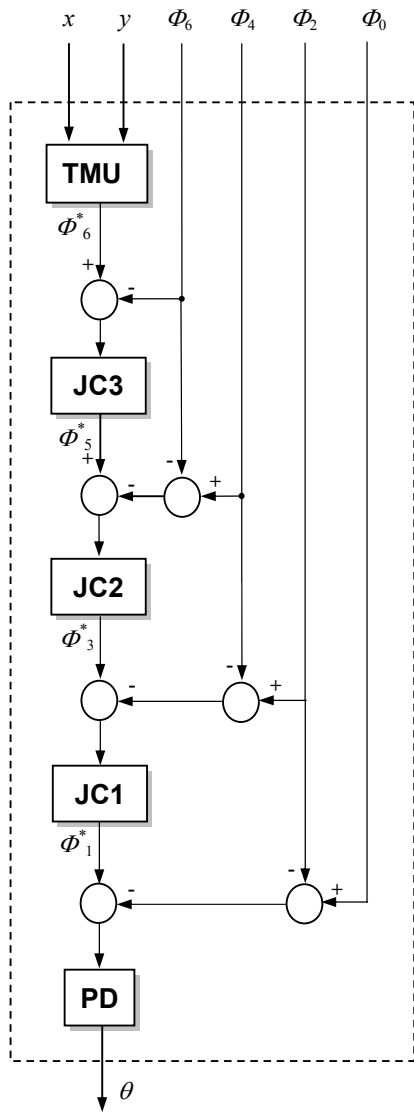

Figure 6. The control system for the three-trailer car

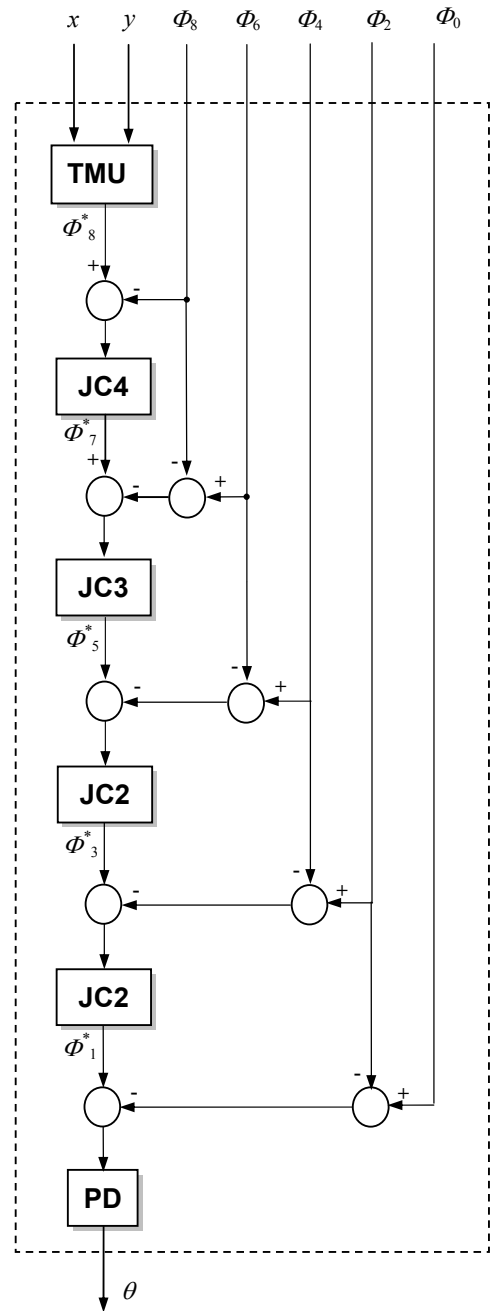

Figure 7. The control system for the four-trailer car

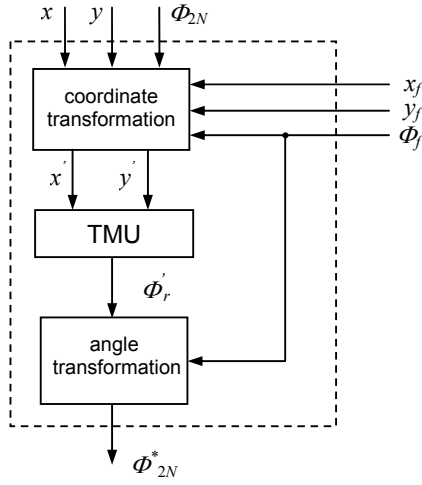

Figure 8. TMU interface

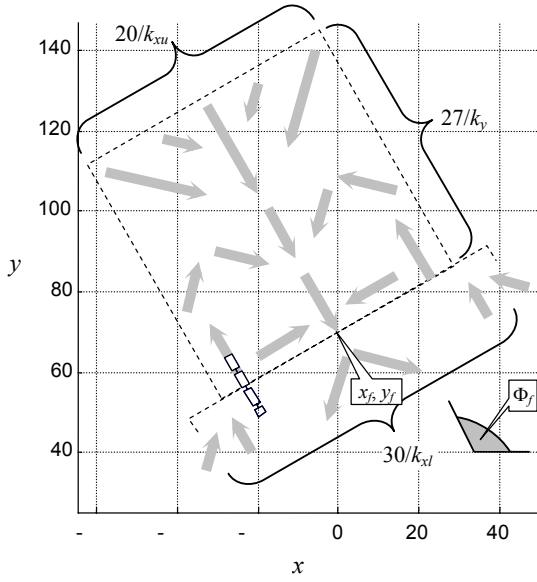

Figure 9. "Force field", generated by TMU

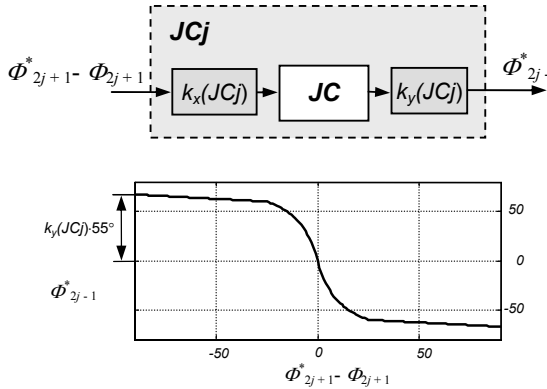

Figure 10. A joint controller

TABLE I
CONTROL SYSTEM PARAMETERS

Parameter	Three trailer system	Four trailer system
k_{xu}	0.2	0.08
$k_{xl}(= 1.2k_{xu})$	0.24	0.096
k_y	0.5	0.2
k_{shift}	30	100
$k_x(JC1)$	0.8	0.3
$k_y(JC1)$	0.2	0.08
$k_x(JC2)$	1.1	1
$k_y(JC2)$	0.8	0.4
$k_x(JC3)$	2	1.3
$k_y(JC3)$	1.5	0.9
$k_x(JC4)$	-	2.5
$k_y(JC4)$	-	1.5
k_p	3	3

TABLE II
TEST DRIVE INITIAL POSITIONS AND RESULTS

System	Test No.	X_0	Y_0	Φ_{j0}	ε
Three trailers	1	0	120	180	0.2157
	2	80	100	0	0.1912
	3	80	20	0	0.4108
	4	-40	30	180	0.2331
Four trailers	1	-100	50	180°	0.6197
	2	-50	200	180°	0.6606
	3	200	50	0°	1.6148
	4	100	-50	0°	1.9127

V. FINE-TUNING THE CONTROL SYSTEM

The general sequence for finding optimal tuning parameters is as follows: first, the goal is to stabilize the system from relatively undemanding starting positions (i.e. Φ_0 is not drastically different from Φ_j and y_0 is not too close to y_j). The rule of thumb for controllability is that $\forall j, k_x(JCj) < k_x(JCj + 1), k_y(JCj) < k_y(JCj + 1)$, because the control action that propagates through the car from the wheels of the cab part should always have more effect to the trailers nearer it.

It is also highly important that the coefficients k_{xu}, k_{xl}, k_y of the TMU should be sufficiently small (proper coordination of lower and upper TMUs requires that $k_{xl} = 1.2 k_{xu}$), i.e. we do not force the trajectories upon the car it is physically unable to follow. Improper definitions of k_{xu} and k_y can easily be another reason for early jackknifing.

Once the stability for undemanding initial positions is achieved we must make sure we are able to maintain control from more difficult positions and if yes, the system must be fine-tuned for best performance by reviewing the values of gain coefficients. It must be noted that low values for $k_y(JCj)$ restrict car's maneuverability thus if they can be increased without jeopardizing stability it must be done. On the other hand, it might be necessary to decrease k_{xl}, k_{xu} and k_y of the TMU even more to give the car enough space to perform expected maneuvers to ensure that the error in the end of backing is as small as possible.

However, when it might seem that each additional trailer

brings along just two additional control parameters, it is however remarkable how much each additional trailer makes the tuning task harder. Granted, it becomes harder and harder to see through the behavior of the system and relate it to the values of those gain coefficients, however, the main reason behind the difficulties is that a more complex multi-trailer system is much more prone to jackknifing and is thus less robust to the control parameter changes. In the end it gives us very little space for the trial-and-error fine tuning procedure. More serious problems start with four trailers where we need to reduce k_{x_u} , k_{y_u} so much for stability's sake that in result the backing trajectories become several times longer. With more trailers (e.g. five trailers with which some preliminary testings were conducted) it is virtually impossible to stabilize the system while backing unless some rigorous mathematical procedure is applied to find suitable control parameters, which remains beyond the scope of current paper. This once again demonstrates that the problem at hand is indeed a very challenging and delicate task.

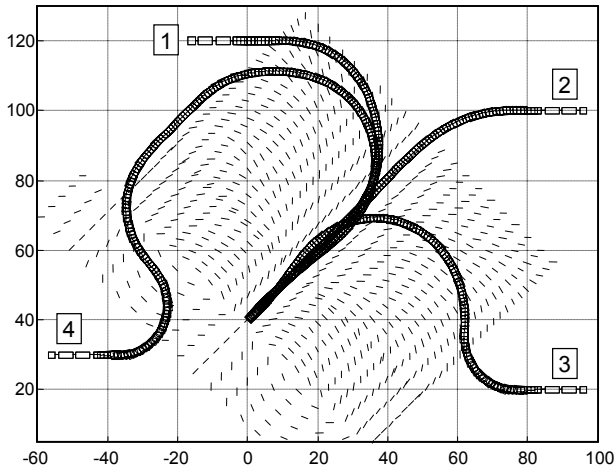

Figure 11. Backing trajectories of the three-trailer car

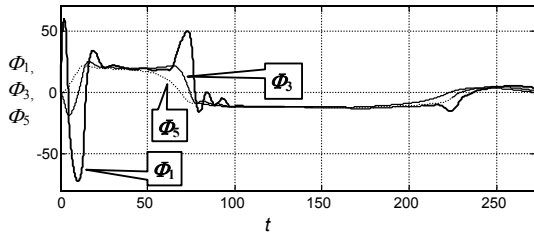

Figure 12. Joint angles during the backing (drive No. 3)

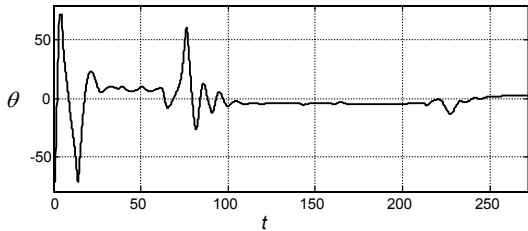

Figure 13. Steering angle during the backing (drive No. 3)

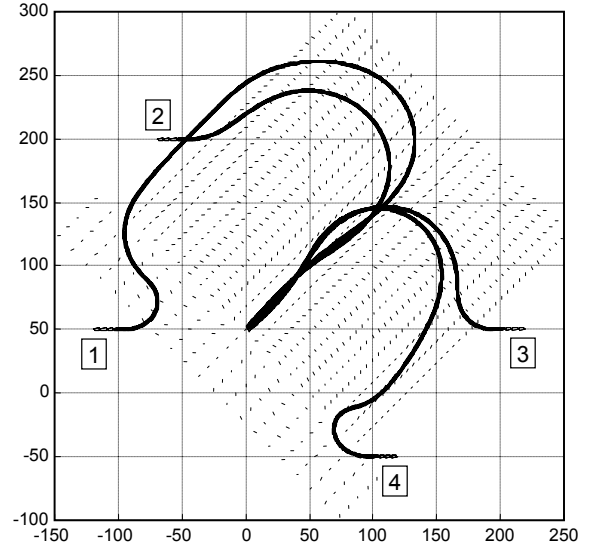

Figure 14. Backing trajectories of the four-trailer car

VI. RESULTS

This section presents the backing results from 8 different initial positions, 4 of them with the three-trailer and four of them with the four-trailer car (Table II) to the loading dock that is situated at $(x_f = 0, y_f = 40)$ with $\Phi_f = 45^\circ$ in first case and at $(x_f = 0, y_f = 50)$ with $\Phi_f = 45^\circ$ in the second case. These positions are selected so that they remain beyond the scaled TMU area, to ensure successful backing (if the initial position is too close to the destination, the car inevitably misses the goal and makes an extra backing loop to position itself properly at the loading dock. The tuning parameters of both control systems are chosen so that a) car maintains stability for all starting positions b) the final backing error evaluated in terms of a weighted sum of distance and orientation errors at the loading dock, computed by

$$\varepsilon = \varepsilon_d + 0.0267\varepsilon_\phi, \quad (4)$$

where

$$\begin{cases} \varepsilon_d = \sqrt{(x_f - x(T_f))^2 + (y_f - y(T_f))^2} \\ \varepsilon_\phi = \text{abs}(\Phi_f - \Phi_4(T_f)) \end{cases}, \quad (5)$$

where T_f is the duration of the backing is as small as possible. These backing errors for all test drives are also given in Table II.

From Table II and corresponding Figs. 11 and 14 we can see that in case of four trailers the backing trajectories (for the sake of the clarity of the illustration, only the trajectories of the last trailers have been drawn at each 20th sampling step) are much longer and even then the backing errors are still quite large (e.g. a backing error of 0.6 is equivalent to the car arriving at the loading dock at the perfect angle and stopping short of 60cm from the destination), which when compared to the total length of the car (17m in case of three-trailer truck and 22m in case of four trailer truck) is quite substantial.

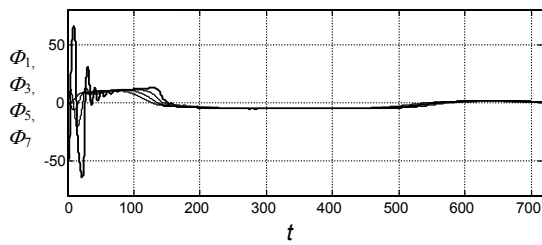

Figure 15. Joint angles during the backing (drive No. 3)

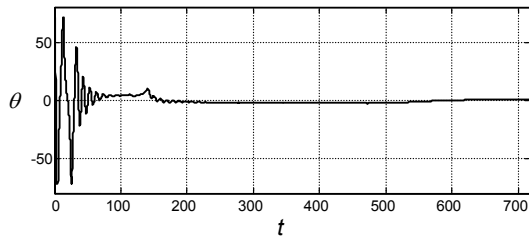

Figure 16. Steering angle during the backing (drive No. 3)

Based on additional information from Figs 12, 13, 15 and 16, which plot the dynamics of joint and steering angles of three- and four-trailer cars during one of the test drives, we can add that in the case of four-trailer car it becomes obvious that most of flexibility has been sacrificed for the sake of stability (all joint angles are almost equal in the second half of the drive). If we remind that even the shortest trajectory takes over 10 minutes to drive through at 0.5 m/s speed then, indeed, it would be much wiser to detach the trailers and back them individually, at this point.

VII. CONCLUSIONS

In this paper we developed control systems for backing three- and four-trailer cars that are capable of steering the car from a sufficiently far-away initial position to the pre-specified loading dock. Problem decomposition leads to hierarchical control systems that focus on trajectory management and subsequent trajectory-driven manipulation of trailer angles. These principal tasks are carried out by very simple standard functional blocks that are implemented by the means of fuzzy logic and are individually adjustable by the means of gain coefficients, whereas additional coordinate transformation block ensures that system is easily reconfigurable when the position of the loading dock is changed. However, as the number of trailers grows it becomes more and more complicated to find an optimal tuning and car's maneuverability is seriously limited because of stability considerations, which makes designing of control systems for the configuration of this complexity largely impractical.

REFERENCES

- [1] S. Geva, J. Sitte, G. Willshire, "A one neuron truck backer-upper," *Proc. Int. Joint Conf. on Neural Networks*, Vol. 2, 1992, pp. 850 - 856
- [2] R.E. Jenkins and B.P. Yuhua, "A simplified neural network solution through problem decomposition: the case of the truck backer-upper," *IEEE Transactions on Neural Networks*, Vol. 4, No. 4, 1993, pp. 718 - 720
- [3] M. Schoenauer and E. Ronald, "Neuro-genetic truck backer-upper controller," *Proc. First IEEE Conference on Evolutionary Computation*, Vol. 2, 1994, pp. 720 - 723
- [4] G. Chen, D. Zhang, "Backing up a truck-trailer with suboptimal distance trajectories 1996., *Proceedings of the Fifth IEEE International Conference on Fuzzy Systems* Vol. 2, 8-11 Sept. 1996 Page(s):1439 - 1445
- [5] R. Parra-Loera and D.J. Corelis, "Expert system controller for backing-up a truck-trailer system in a constrained space," *Proc. 37th Midwest Symposium on Circuits and Systems*, Vol. 2, 1994, pp. 1357 - 1361
- [6] Y. Jianqiang, N. Yubazaki and K. Hirota, "Backing up control of truck-trailer system," *Proc. 10th IEEE International Conference on Fuzzy Systems*, Vol. 1, 2001, pp. 489 - 492
- [7] N. Zimic and M. Mraz, "Decomposition of a complex fuzzy controller for the truck-and-trailer reverse parking problem," *Mathematical and Computer Modelling*, Vol. 43, No. 5-6, 2006, pp. 632-645
- [8] C. Altafini, A. Speranzon and B. Wahlberg, "A Feedback Control Scheme for Reversing a Truck and Trailer Vehicle", *IEEE Trans. Robotics and Automation*, Vol. 17, No 6. 2001, pp. 915- ???
- [9] J. R. Koza, "A genetic approach to finding a controller to back up a tractor-trailer truck," *Proc. 1992 American Control*, 1992, pp. 2307-11.
- [10] S. K. Halgamuge, T. A. Runkler, and M. Glesner, "A hierarchical hybrid fuzzy controller for realtime reverse support of vehilces with long trailers," *Proc. Third IEEE Conf. on Fuzzy Systems*, 1994, pp. 1207-1210.
- [11] D. F. Hougen, M. Gini, and J. Slagle, "Rapid unsupervised connectionist learning for backing a robot with two trailers," *Proc. IEEE Int. Conf. on Robotics and Automation*, Albuquerque, 1997, pp.2950-2955.
- [12] Y. Nakamura, H. Ezaki, Y. Tan, and W. Chung, "Design of steering mechanism and control of nonholonomic trailer systems," ????
- [13] G. S. Kong and B. Kosko, "Adaptive fuzzy systems for backing up a truck and trailer," *IEEE Trans. Neural Networks*, vol. 3, pp. 211-223, 1992.
- [14] D. H. Kim and J. H. Oh, "Experiments of backward tracking control for trailer systems," *Proc. 1999 IEEE Int. Conf. on Robotics and Automation*, Detroit, 1999, pp. 19-22.
- [15] D. Nguyen and B. Widrow, "The truck backer-upper: An example of self-learning in neural network," *IEEE Contr. Syst. Mag.*, Vol. 10, No. 2, 1990, pp. 18-23
- [16] K. Tanaka, T. Taniguchi and H.O. Wang, "Model-based Fuzzy Control for Two-Trailers Problem: Stability Analysis and Design via Linear Matrix Inequalities," *Proc. 6th IEEE Int. Conf. Fuzzy Syst.*, Barcelona, Spain, 1997, pp. 343-348
- [17] K. Tanaka, S. Hori and H.O.Wang, "Multiobjective Control of a Vehicle with Triple Trailers," *IEEE/ASME Trans. Mechatronics*, Vol. 7, No. 3, 2002, pp. 357-368
- [18] K. Tanaka, T. Kosaki, H.O. Wang, "Backing Control Problem of a Mobile Robot with Multiple Trailers: Fuzzy Modeling and LMI-Based Design," *IEEE Trans. on Systems, Man and Cybernetics, Part C*, Vol. 28, No. 3, 1998, pp. 329-337
- [19] A. Riid and E. Rüstern, "Fuzzy logic in control: truck backer-upper problem revisited," *Proc. 10th IEEE International Conference on Fuzzy Systems*, Melbourne, Vol. 1, 2001, pp. 513-516.
- [20] A. Riid and E. Rüstern, "Fuzzy Hierarchical Control of Truck and Trailer," *Proc. 8th Biennal Baltic Electronic Conf.*, Tallinn, Estonia, 2002, pp. 141-144.
- [21] A. Riid, A. Leibak and E. Rüstern, "Fuzzy Backing Control of Truck and Two Trailers," *Proc. IEEE International Conference on Computational Cybernetics*, Tallinn, 2006, pp. 107-112.

- [22] A. Riid, Dmitri Pahhomov and E. Rüstern, "Car Navigation and Collision Avoidance System with Fuzzy Logic", *Proc IEEE International Conference on Fuzzy Systems*, Budapest, Vol. 3, 2004, pp. 1443-1448.